

NPN

New Product News



CUTSFEED
HIGH FEED PARTING



Single-Ended Rigid Inserts and Holders for Parting and Deep Grooving

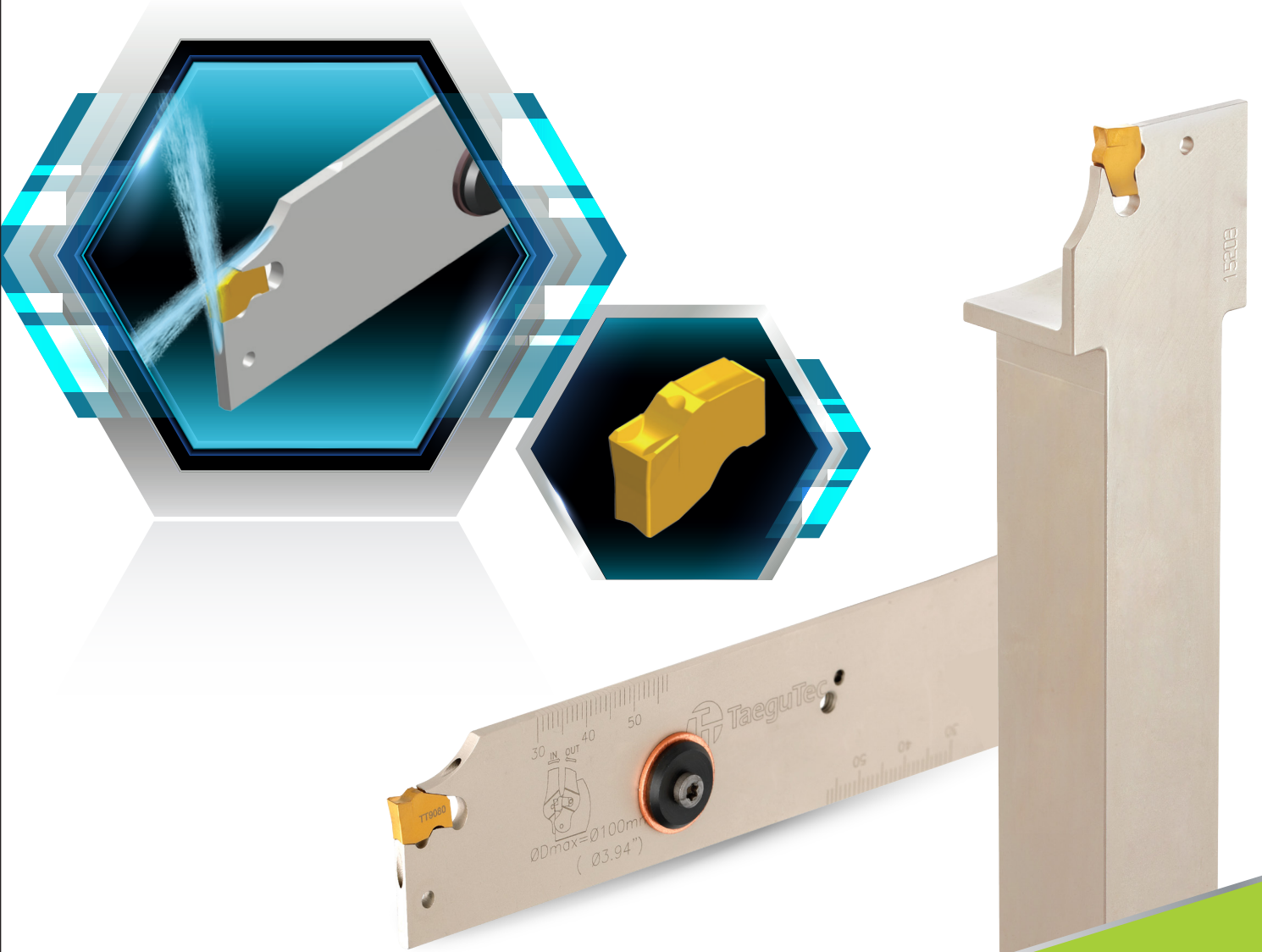

KEY POINT

TaeguTec has launched the CUT-SFEED, a new line of single-ended rigid inserts and holders for parting and deep grooving

For parting or deep grooving applications, single-ended self-grip inserts are generally used but are susceptible to vibrations due to structural weakness as well as unstable tool life and frequent breakage stemming from bad chip evacuation.

The **CUT-SFEED** line is designed as a thicker height insert and includes a specialized three-area contact with bottom-stopper, which is more robust and stable than the conventional self-grip type. Therefore, it enables improved surface roughness, insert position repeatability and tool life even under tough machining conditions.

The holders are available in two types: a square shank type (SFER/L), a blade type (SFGB). All holders use the COOL-BURST high pressure coolant system and come as standard products.

Features

- Rigid clamping of the specialized three-area contact design for excellent durability and repeatability
- Insert's increased height enhances rigidity
- User-friendly insert clamping system
- COOL-BURST holders are available as standard items
 - Stable and improved tool life and improved chip evacuation
- Maximum cutting diameter: Ø100 mm (blade), Ø60 mm (square holder)



Robust clamping structure and a higher rigidity insert

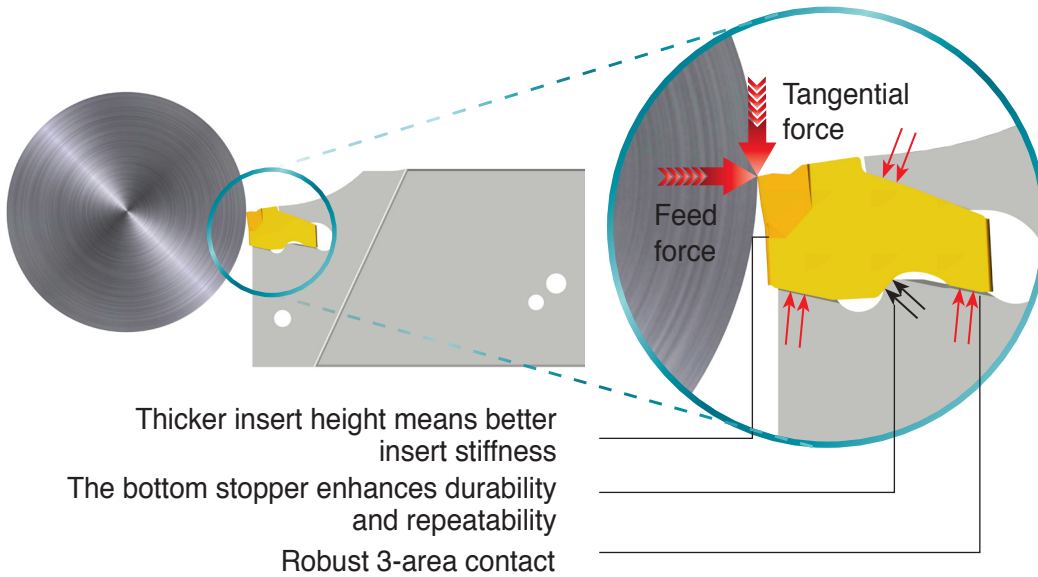

Self-grip's convenient insert clamping method

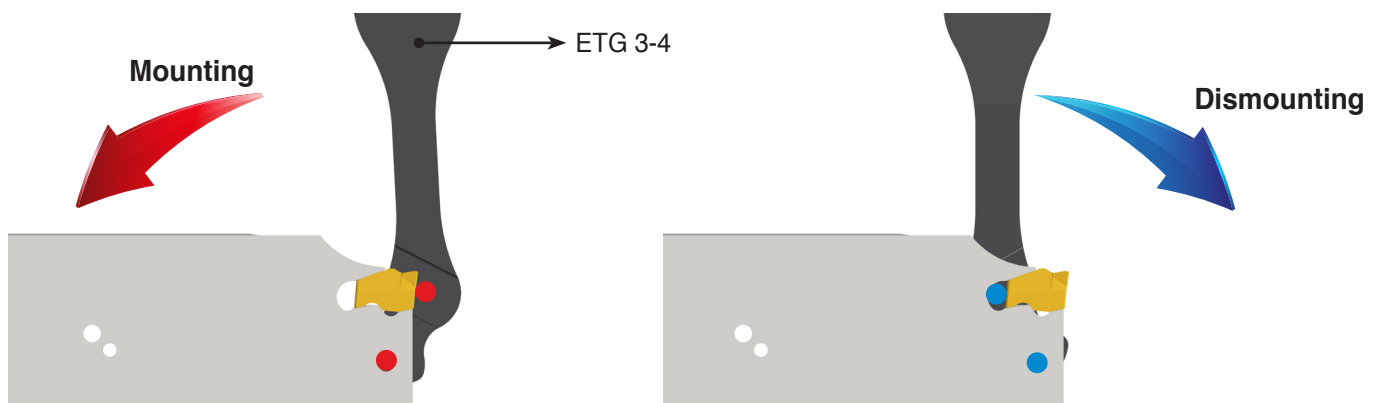

Upper and lower dual high pressure coolant channels

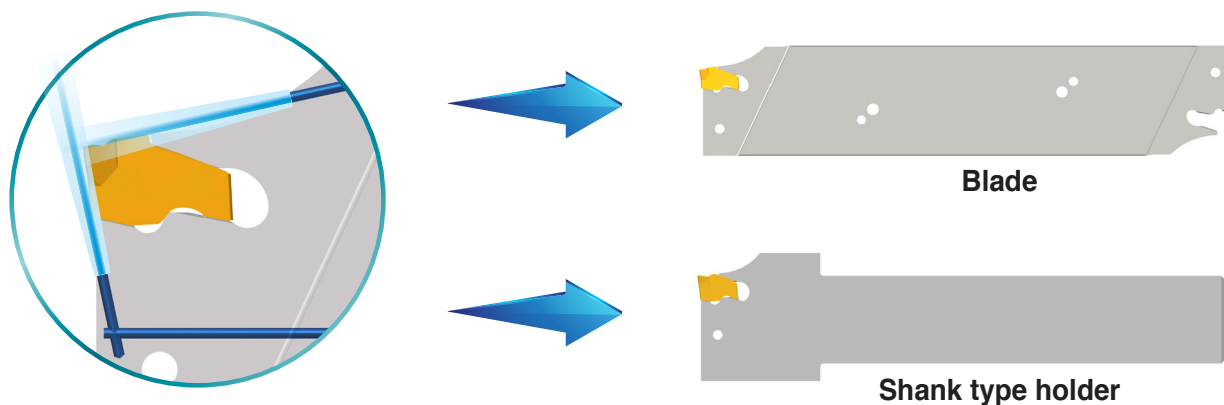

SFGB-TB



Blades for parting and deep grooving with high-pressure coolant



COOLBURST
PINPOINTED COOLANT

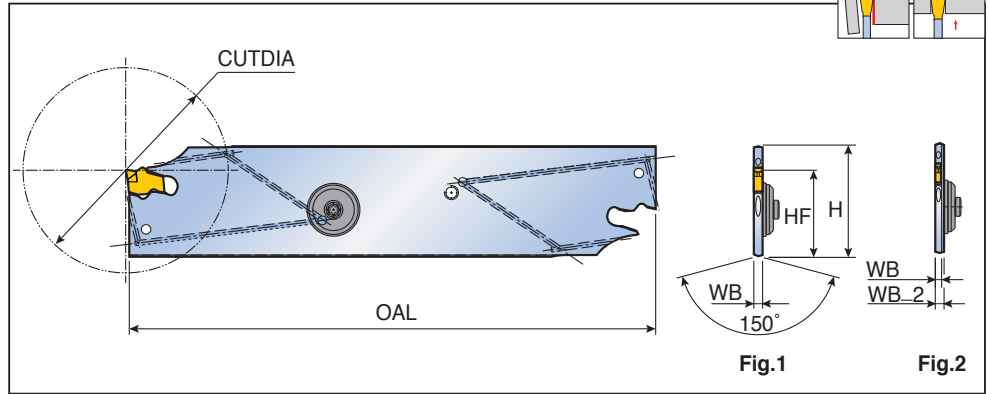

| Designation | Insert seat size | Dimension (mm) | | | | | | Fig. | Block | Insert |
|---------------------|------------------|----------------|------|-----|-----|------|--------|------|-----------|--------|
| | | H | HF | OAL | WB | WB_2 | CUTDIA | | | |
| SFGB 32-2-TB | 2 | 32 | 24.8 | 150 | 1.8 | 2.5 | 50 | 2 | TTBU..-TB | SFC |
| 32-3-TB | 3 | 32 | 24.8 | 150 | 2.5 | - | 100 | 1 | | SFJ |
| | | | | | | | | | | |
| | | | | | | | | | | |
| | | | | | | | | | | |
| | | | | | | | | | | |
| | | | | | | | | | | |

| | 70 bar flow rate (ℓ/min) | 100 bar flow rate (ℓ/min) | 140 bar flow rate (ℓ/min) |
|---------------------|--------------------------|---------------------------|---------------------------|
| SFGB 32-2-TB | 10-12 | 12-14 | 15-17 |
| 32-3-TB | 19-21 | 23-25 | 27-29 |
| | | | |

Spare parts

| Designation | Sealing screw set | Extractor | | |
|-----------------|-------------------|-----------|--|--|
| | | | | |
| SFGB -TB | SGC 340 | ETG 3-4 | | |
| | | | | |
| | | | | |
| | | | | |

• Extractor should be ordered separately

TTBU-TB

Blocks for blades with high pressure coolant

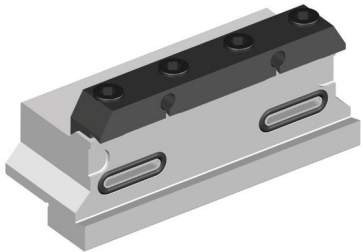

COOLBURST
POWERIZED COOLANT

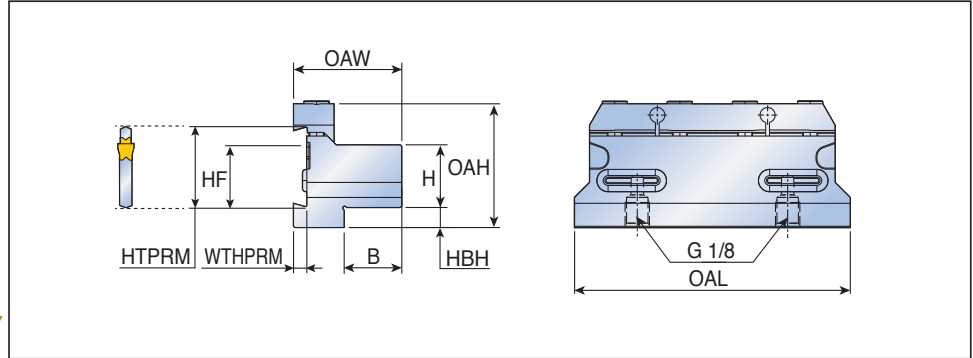

| Designation | Dimension (mm) | | | | | | | |
|----------------------|----------------|-------|----|-----|------|--------|-----|------|
| | H | HTPRM | B | HBH | OAH | WTHPRM | OAL | OAW |
| TTBU 20-32-TB | 20 | 32 | 19 | 15 | 36.4 | 5.3 | 100 | 39.2 |
| 25-32-TB | 25 | 32 | 23 | 8 | 41.4 | 5.3 | 110 | 43.2 |
| 32-32-TB | 32 | 32 | 29 | 5 | 48.4 | 5.3 | 110 | 49.2 |
| | | | | | | | | |
| | | | | | | | | |
| | | | | | | | | |
| | | | | | | | | |
| | | | | | | | | |
| | | | | | | | | |

Spare parts

| Designation | Screw | Clamp | O-ring | Wrench | |
|----------------------|-----------------|---------|-----------------|--------|--|
| | | | | | |
| TTBU 20-32-TB | SR M6X16 DIN912 | BKU 100 | O-RING ID14X2.5 | L-W 5 | |
| TTBU 25-32-TB | SR M6X16 DIN912 | BKU 110 | O-RING ID14X2.5 | L-W 5 | |
| TTBU 32-32-TB | SR M6X16 DIN912 | BKU 110 | O-RING ID14X2.5 | L-W 5 | |
| | | | | | |
| | | | | | |
| | | | | | |



SFER/L-TB

External holders for parting and deep grooving with high-pressure coolant

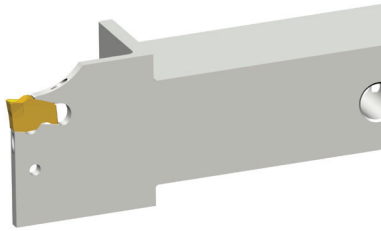

COOLBURST
HIGH PRESSURE COOLANT

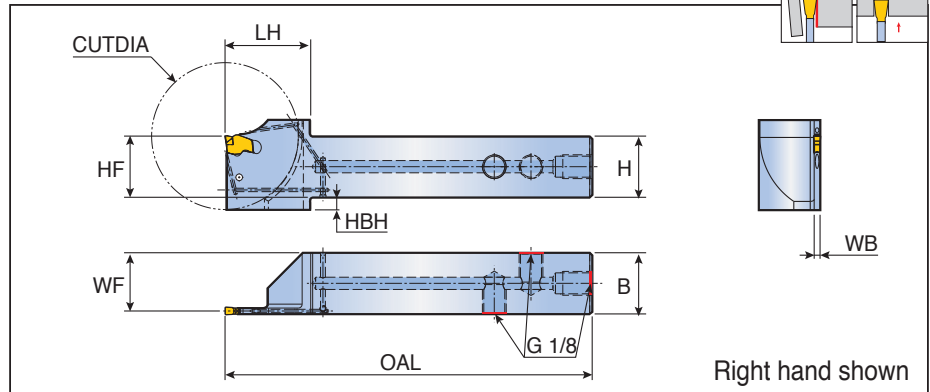

Right hand shown

| Designation | Insert seat size | Dimension (mm) | | | | | | | | | Insert |
|--------------------------------|------------------|----------------|----|----|-----|----|------|-----|-----|--------|--------|
| | | H | HF | B | OAL | LH | WF | WB | HBH | CUTDIA | |
| SFER/L 2525-2T25-D50-TB | 2 | 25 | 25 | 25 | 150 | 32 | 24.1 | 1.8 | - | 50 | SFC |
| 2525-3T30-D60-TB | 3 | 25 | 25 | 25 | 150 | 35 | 23.8 | 2.4 | 5 | 60 | SFJ |
| | | | | | | | | | | | |
| | | | | | | | | | | | |
| | | | | | | | | | | | |
| | | | | | | | | | | | |
| | | | | | | | | | | | |

| | 70 bar flow rate (ℓ/min) | 100 bar flow rate (ℓ/min) | 140 bar flow rate (ℓ/min) |
|--------------------------------|--------------------------|---------------------------|---------------------------|
| SFER/L 2525-2T25-D50-TB | 10-12 | 12-14 | 15-17 |
| 2525-3T30-D60-TB | 14-16 | 17-19 | 21-23 |
| | | | |

Spare parts

| Designation | Plug  | Wrench  | Extractor  | |
|------------------|---|---|--|--|
| SFER/L-TB | PLG G1/8-L6.5 | L-W 5 | ETG 3-4 | |
| | | | | |
| | | | | |
| | | | | |

• Extractor should be ordered separately

SFC



Single-ended inserts for parting and deep grooving with C-Type chip breaker

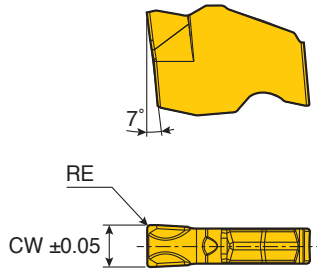

| Size | Dimension (mm) | | | |
|------------|----------------|-----|--|--|
| | CW | RE | | |
| 1.6 | 1.6 | 0.2 | | |
| 2 | 2.0 | 0.2 | | |
| 3 | 3.0 | 0.2 | | |
| | | | | |
| | | | | |
| | | | | |
| | | | | |
| | | | | |
| | | | | |

| Insert | Designation | Insert seat size | Feed (mm/rev) | Cermet | | | Coated | | | Uncoated | | | |
|--------|----------------|------------------|---------------|--------|--|--|--------|--------|--------|----------|--------|--------|-----|
| | | | | CT3000 | | | TT7505 | TT6080 | TT5100 | TT9080 | TT7220 | TT8020 | K10 |
| | SFC 1.6 | 1 | 0.05-0.15 | | | | | | ● | | ● | | |
| | 2 | 2 | 0.08-0.20 | | | | | | ● | | ● | | |
| | 3 | 3 | 0.10-0.25 | | | | | | ● | | ● | | |

●: Standard items

SFJ



Single-ended inserts for parting and deep grooving with J-Type chip breaker

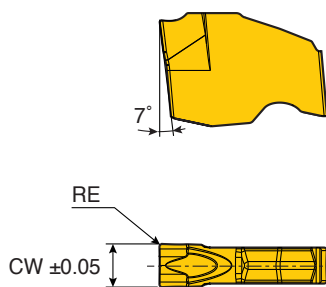

| Size | Dimension (mm) | | | |
|----------|----------------|-----|--|--|
| | CW | RE | | |
| 2 | 2.0 | 0.2 | | |
| 3 | 3.0 | 0.2 | | |
| | | | | |
| | | | | |
| | | | | |
| | | | | |
| | | | | |
| | | | | |
| | | | | |

| Insert | Designation | Insert seat size | Feed (mm/rev) | Cermet | | | Coated | | | Uncoated | | | |
|--------|--------------|------------------|---------------|--------|--|--|--------|--------|--------|----------|--------|--------|-----|
| | | | | CT3000 | | | TT7505 | TT6080 | TT5100 | TT9080 | TT7220 | TT8020 | K10 |
| | SFJ 2 | 2 | 0.05-0.15 | | | | | | ● | | ● | | |
| | 3 | 3 | 0.08-0.20 | | | | | | ● | | ● | | |

●: Standard items

KIT COLLECTIONS

These kit products are available in the format listed below.



| Cat. No. | Designation | Bill of materials | Qty. |
|----------|----------------------------------|-------------------|------|
| 6334854 | KISFT-SFGB 32-1.6C TT9080 | SFGB 32-1.6 | 1 |
| | | SFC 1.6 TT9080 | 3 |
| | | ETG 3-4 | 1 |
| 6334855 | KISFT-SFGB 32-2C-TBTT9080 | SFGB 32-2-TB | 1 |
| | | SFC 2 TT9080 | 3 |
| | | ETG 3-4 | 1 |
| 6334856 | KISFT-SFGB 32-3C-TBTT9080 | SFGB 32-3-TB | 1 |
| | | SFC 3 TT9080 | 3 |
| | | ETG 3-4 | 1 |



| Cat. No. | Designation | Bill of materials | Qty. |
|----------|----------------------------------|-------------------|------|
| 6337915 | KISFS-SFGB 32-1.6C TT9080 | SFGB 32-1.6 | 1 |
| | | SFC 1.6 TT9080 | 20 |
| | | ETG 3-4 | 1 |
| 6337916 | KISFS-SFGB 32-2C-TBTT9080 | SFGB 32-2-TB | 1 |
| | | SFC 2 TT9080 | 20 |
| | | ETG 3-4 | 1 |
| 6337917 | KISFS-SFGB 32-3C-TBTT9080 | SFGB 32-3-TB | 1 |
| | | SFC 3 TT9080 | 20 |
| | | ETG 3-4 | 1 |



| Cat. No. | Designation | Bill of materials | Qty. |
|----------|-------------------------------|-------------------|------|
| 6338468 | KISFF-A-SFC 1.6 TT9080 | SFC 1.6 TT9080 | 100 |
| 6338469 | KISFF-B-SFC 1.6 TT9080 | | 300 |
| 6338470 | KISFF-A-SFC 2 TT9080 | SFC 2 TT9080 | 100 |
| 6338471 | KISFF-B-SFC 2 TT9080 | | 300 |
| 6338472 | KISFF-A-SFC 3 TT9080 | SFC 3 TT9080 | 100 |
| 6338473 | KISFF-B-SFC 3 TT9080 | | 300 |